

## Art 255 – Black and White Film and Darkroom Photography

Instructor: Julia Paull, Associate Professor of Teaching



Image Credit Christopher Williams Cutaway model Nikon EM. Shutter (2007)



**ART 255 Black and White Film and Darkroom  
Photography**  
**Fall 2022 Units: 4**  
**M W 12-- 2:40**  
**Section: 33870R**

**Location:** Harris 211  
**Email:** [jpaull@usc.edu](mailto:jpaull@usc.edu)  
**Phone:** 213 740-2787 (main office)  
**Office:** IFT Advanced photography Lab, 3001 S Flower St  
**Office Hours:** MW by appointment before class Harris Hall. *Please reach out if you have any concerns about the course.*  
**Email Office hours:** M T W Th I will get back to within 48 hours within regular business hours.

**Beginning Lab Cage:** Jon Wingo  
**Office:** Beginning photography lab  
**Contact Info:** Tel: (213) 740-7431, [wingo@usc.edu](mailto:wingo@usc.edu),

**Advanced Photography Lab:** Jacqueline Castillo  
**Office:** IFT Facility  
**Contact Info:** Tel: 213743-2017 [jc99027@usc.edu](mailto:jc99027@usc.edu)

**Intermedia Computer Lab (Galen Lab):** Michael Shroads  
**Contact Info:** [shroads@usc.edu](mailto:shroads@usc.edu)

**IT Help:** Nikhil Murthy, Harris Hall  
**Hours of Service:** 9-5pm  
**Contact Info:** [roskiit@usc.edu](mailto:roskiit@usc.edu).  
(See Technological Proficiency and Hardware/Software Required. After filling out survey, use this email for any issues related to school provided Adobe CC software)

**Architecture and Fine Arts Library, Watt Hall Basement**  
**Research Help:** Stacey Williams, Head of the AFA Library  
**Hours of Service:** 9-5  
**Contact Info:** [stacyw@usc.edu](mailto:stacyw@usc.edu), +1 213 740 8646

## **Course Description**

This analog, film-based course introduces students to 35mm-camera basics and black-and-white wet lab procedures for darkroom photography. Students will be introduced to and utilize the photogram, pinhole camera, 35mm cameras, black and white darkroom techniques, metering, film development, retouching, fiber printing and final presentation strategies. In addition, we will examine historic precedents and contemporary photographic issues through readings, informal lectures, discussions, and experimentation, synthesizing into a self-organized final project. This course introduces and expands students' understanding of photographic aesthetic, historical, and contemporary work, while exposing them to relevant issues and concerns of the medium. As a lab-based practice, film photography embodies the process of experimentation, trial and error, leading to a nuanced understanding of failure and success in the study of images made with light.

The goal of this course is to produce thoughtful, compelling and technically proficient black and white darkroom photographs.

## **Learning Objectives**

There are a series of photographic assignments starting out with the more technical and ending the semester with a longer self-designed project. The first part of the semester will focus on the development of technical skills - camera, negative, print, and lighting as it relates to photographic compositions and meaning. For the remainder of the semester the focus is on pursuing individually compelling subjects and translating them into compelling photographs. Additionally we will examine historic precedents and contemporary art issues related to photography through readings and informal lectures, discussion of ideas, experiments, and material developments, culminating in a self-organized final project. Students also conduct research on a contemporary photographic artist who inspires them and give a 10-minute presentation to their peers. In addition to darkroom time, the course includes critiques, field trips, individual meetings, photographic lectures, discussions and short related photographic readings in order to meet the learning objectives below.

1. Understanding of the phenomena of photography through pinhole cameras, photograms, and basic use of the darkroom
2. Ability to operate 35 mm format film cameras, with an understanding of metering, depth of field, focus, and composition.
3. Introduces knowledge of the fundamentals of looking at light, either constructed by the nuisances of sunlight or through a basic introduction to metering and basic studio lighting. Addresses how space and light affect subject matter and photographic meaning.
4. Working knowledge of film development, contact printing, film scanning
5. Mastery of darkroom printing on RC paper with black and white enlargers. Introduction to fiber archival printing.
6. Introduces a variety of genres of photography and encourages the production of original work by self-generating ideas, proposing working methods with the goal of working toward creating independent photographic projects.

7. Increases critical thinking skills as they relate to making, looking at and discussing photographic artworks by developing, analyzing and articulating the relationship between the content and form in photographs made during the semester. Practiced through readings, discussions, and critiques
8. Addresses contemporary and historical photographic precedents in art making by conducting research on a contemporary artist who resonate with artistic goals through readings, library research and presentation on a contemporary artist working in photography.

### **Covid**

You are expected to follow government parodical for masking. Be considerate of your community by taking care of your health and staying home when you are ill.

### **Course Notes**

**This course stores information on blackboard and google drive. google drive link:**

[https://drive.google.com/drive/folders/1fTP5PSCZ40fXUhbOnfz-5akT0tYyUbjT?usp=drive\\_link](https://drive.google.com/drive/folders/1fTP5PSCZ40fXUhbOnfz-5akT0tYyUbjT?usp=drive_link)

Access to Adobe Suite. See Blackboard announcements.

### **Field Trip Forms**

Can be found under the Roski website under student forms or via the below link:

[https://roski.usc.edu/sites/default/files/Roski%20Travel%20form-%20Students%20Carpool\\_oct2018.pdf](https://roski.usc.edu/sites/default/files/Roski%20Travel%20form-%20Students%20Carpool_oct2018.pdf)

During class students practice skills necessary to make quality work. Being in class, actively participating is essential and has an impact on your grade. Demonstrations and equipment introductions via lectures are presented once. Phones need to be stored for the duration of class. In the darkroom phone screens will fog photographic paper. Students who miss class must acquire missed information by conducting library research, reading, and on line video searches. Consult the syllabus and contact a classmate to learn what happened during a missed class.

### The Enlarger

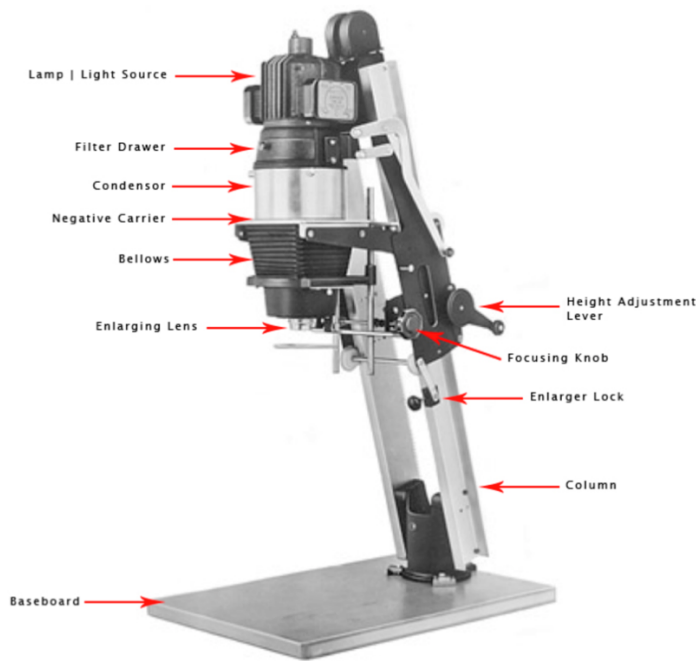

### Lab Time

Part of making photographs is learning effective time management. Lab time is designed for developing film, printing, studio lighting shoots, and individual meetings. Come prepared, and ready to work. All shooting with the exception of studio lighting, happens outside of class time. Expect to shoot a roll of film every week. Expect some film not to turn out. This course is designed to leave room for film failure and time for reshooting each assignment. Edit photographs outside of class time. Come to class ready to develop film and print in the darkroom. Students unprepared for class, who need to leave to get materials, or proper shoes and/or pants may find it challenging to keep up with the class. Consider leaving pants and close toed shoes in your locker.

While there is a fair amount of lab time during class, it will be necessary to develop and print on outside of class as well. Consult the darkroom calendar. As a 4 unit course expect to spend 8 hours a week on this course. Students who plan their time well and plan ahead, and use class lab time to print, excel in the darkroom.

### Contact Sheets



Detail Robert Frank Contact Sheet

Students are required to show contact sheets during lab time and on calendar dates indicated. Contact sheets should include at least 24-36 photographs per contact sheet and be legible for darkroom use. Contact sheets mirror how an image will print and provide a roadmap to the order of making prints. It has an impact on students capacity to produce quality work. Contact sheets are also to be submitted with photographic work on the day of critique. Be sure to include all contact sheets, even for works edited out, as the amount of film shot reflects the amount of learning taking place.

### **Sample test strip.**



Making test strips is essential to making a good print. A good test strip may take longer to make in many cases than a good print. It is the guide to proper exposure.

### **Wet and dry areas**

Labs have wet areas and dry areas and it is necessary to keep the two separated in order to produce good work. These will be taught and students will be reminded of these two areas of the lab throughout the semester. In other words, hold trays until returning them to the sink from which they came. Dry hands before touching photo paper, film and enlarger stations.

**Critiques and discussions** Come prepared and stay on point. Thoughtfully respond to photographs and texts using polite language. Be mindful of the amount of time available for everyone to speak. Express your thoughts so your peers have the opportunity to hear expanded points of view. During critique it is not your job to remake your classmates work, but rather to question and comment on the photographs as viewed and interpreted.

### **Individual Meeting**

Usually occur during lab time. Students are expected to bring all relevant materials, negatives, contact sheets, work prints, notes and fine mounted prints for discussion. It is helpful to think about artistic goals and prepare a list of questions or topics you want to discuss ahead of time.

### **Documentation of photographic works**

Documentation of all creative projects are to be submitted via drop box on the day the project is due. You will be invited to the dropbox folder at the beginning of the semester. Files should be submitted as jpegs and scaled 8 x 10, 300 DPI

Title as follows: Last Name\_First Name\_Title.extension

(Example: Doe\_Jane\_BestPieceThusFar\_.jpeg)

## Description and Assessment of Assignments

### Required Readings and reading responses (INQUIRY)

Articles are available via link on the syllabus or on blackboard as indicated in the calendar. Readings are useful to tune one's position on art making in a photographic context while working towards a well-developed individual artist point of view.

Students turn in inquires (written responses) on the calendar day that indicate a reading is due. Print the reading, underline points of interest, confusion, curiosity, and write 3 in-depth questions or comments on the article for discussion. Use the back of the last page of the text for this. Come to class with the reading prepared to share comments and questions. Inquiries are not accepted late or via email. If a student's printer is broken they are welcome to hand write inquiries. Inquiries that fail to demonstrate working knowledge of the readings will be returned with no credit.

### Assignment #1

6 -10 8 x 10 inch prints of photogram and/or pinhole camera prints that explore one theme.

The Goal of this assignment is to work on composition, meaning, and darkroom techniques (proper exposures, understanding the enlarger and printing). Students are welcome to focus more on the pinhole camera or the darkroom or both. Write your name on the back of each page submit in semester folder. At least 2 prints need to be a positive.

#### Assessment

Following guidelines and turning work in on time  
Composition  
Print quality  
Progression of abstraction and/or development of ideas  
Relationships between prints

**ARTIST PRESENTATION ASSIGNMENT** - research & present a photographer  
20 images Max 10 minute talk

Each student will presents a different artist. Choices are given on a first requested first received basis email [jpaul@usc.edu](mailto:jpaul@usc.edu) - pick three artists, header for email: 255/name of artists in form of the example below' your first initial and last name Adams Robert/Sherman Cindy/Doe Jane. Indicate your first second and third choice in the email. I will email back with the photographer to present.

At the time of your presentation provide all the members of the class with a written hard copy summary of the artist you will be talking about. This written (max 2 page) handout should include the relevant information about the artist as well as websites (artist website and gallery websites) and a minimum of two book references. (Title, Author, page #s and ISBN) .

#### FINDING AN ARTIST

Spend a couple of hours in the Art and Architecture Library located in the basement of Watt Hall looking at photo books. Most are in the 'TR' section of the library. Check out the MOMA collection + <https://www.moma.org/calendar/groups/1>, Aperture <https://aperture.org> ,

Artforum, Frieze, Cabinet, Blindspot Magnum photo <https://www.magnumphotos.com>, and galleries that show photography such as <https://www.303gallery.com/artists>, <https://www.gladstonegallery.com/artists>, And so on. Part of this assignment is just to spend time looking at art.

#### IMAGE QUALITY FOR 20 + PHOTOGRAPHS PRESENTED

Create a power point or keynote document and bring in the file on a USB as Harris 211 or download from the cloud to the computer in the classroom. For images make scans, or use the copy stand & digital camera in the Harris lab to document images in books. For screen grabs make sure the file size is large. jpegs sized 8 x 10 inches; 150 dpi works well. Presentations with poorly exposed or degraded images will be marked down.

#### CONTENT OF THE TALK

Be concise. Include important facts about the artist life and the circumstances which form them but concentrate on their artistic career.

What concepts are/were they interested in? How does their art reflect this?

Show 3-4 bodies of work by the artist and address the concept, method of working, titles for work, materials - camera/equipment, printing methods, scale etc.

#### ASSESSMENT

Following all guidelines, meeting all due dates

Quality of images

Organization of presentation, relationship between what is said and what we are looking at

Depth of knowledge on artist

Ability to speak up and engage viewer in why the photographers work is important

#### **Assignment #2 The Negative and The Print**

1 contact sheet, 1 print, & 1 written description in a folder

Assignment 2 first roll of film

Load your camera with film and go for a walk someplace appealing, or significant to you. You can interpret the idea of a walk loosely. Do not take your walk on campus (unless you can transform campus into nothing any of us has ever seen before). When you see something you want to photograph, take the picture. You cannot look back or take a photograph of something you saw earlier that you now think you like better. You can only move forward. Shoot the entire roll of film in one walk. As you photograph look to make the most interesting compositions you can with each subject.

As you do this assignment try out the following "technical things" with your camera. Later go back and indicate on the back of your proof sheet which negative number corresponds to each technical area. You may not get results for all these areas.

pictures:

1 - 3 Bracketing. Take a picture at the exposure time your in camera meter recommends, take another picture of the exact same thing only doubling your shutter speed, and another exposure cutting your shutter speed in half.

4 - 5 Speed. Take a picture of an object moving swiftly past you using a slow shutter speed (1/60 or lower) and another using a fast shutter speed (1/500 or faster).

6 - 7 Depth of field. Make 2 exposures of the same subject making certain that there is an object in the foreground (about 5 feet from the camera), an object in the middle ground (about 10 feet from the camera), and in the background (20 feet or more from the camera). use a low numbered F stop (F 4 or F 2.8) for 1 exposure, and a high numbered F-stop (F 16 or F 22) for the other.

8 - 10 Lighting. Make 3 exposures, one with the sun behind you (front light), the second with the sun behind the subject (back light) and the last using side light.

11 - 13 Metering. Take a picture using the suggested meter reading in your camera. Take a light reading off of the ground and use that meter reading to take the picture you just took. Move up as close as possible to the subject and take a light reading, then shoot the same picture as the previous two photographs.

Edit pictures to pick out four images that represent your experience/observations of this walk. Think about how the pictures relate to each other and why you picked them.

Written Description

When you have made your print, write a description of what the image means to you and what you see in it. Typed!!

Assessment

Following guidelines and turning in all work on time

Composition

Quality of negatives

Print quality

Complexity and depth of print

**Assignment #3.** Displacement or The indirect Subject.

6 + prints & 2 – 3 contact sheets/rolls of film

How do we address photographically subjects that are not directly in front of us? Think Climate Change, colonialism, the past, the future.... How do we photograph that which is physically absent yet impactful to us personally and/or society as a whole? Make a set of photographs that speak to a subject of import to you despite its indirect access.

The USC campus should not present itself in any form of your photographs unless it is truly the content of the work in which case it needs to be specific.

Assessment:

Following guidelines and turning in all work on time

Composition in relation to content

Negative/print quality

Complexity and depth of idea

Complexity of relations relationship between images

**Assignment #4** Documents and/or testing a longer term idea for the final

5 + prints & 3+ contact sheets (three rolls of film)

Create photographs on the subject of your choice that embody your response to the reading *What is a Document*: an exchange between Thomas Keenan and Hito Steyerl. The photographs for this project need to have some connection to each other. You are welcome to add text to this project

Assessment

Planning, and execution, turning work in on time

Depth of knowledge and visual communication of topic – ability to make subject compelling

Negative & print quality

Complexity of ideas communicated

Complexity of form as it relates to content

### **Assignment #5 SELF DIRECTED**

set of 8 or more photographs, 4 contact sheets (four rolls of film)

Each photograph should relate in some way to the next and previous. The relationships don't necessarily have to remain the same. The presentation of the set of photographs needs to show some related logic.

Some kinds of relations:

**1. Associative** - Joined in companionship, united in action or purpose, allied, combined in classification.

**2. Intuitive** - Of knowledge or mental perception without the intervention of any reasoning process, obvious to the senses.

**3. Formal** - Of or pertaining to shape, configuration, the visible aspect of things, type.

**4. Causative** - Pertaining to that which produces an effect; that which gives rise to an action, phenomenon or condition.

**5 Time** - ...

*You may come up with other kinds of relationships. This is not necessarily a complete list.*

The **presentation** of your work needs to relate directly to the content of the photographs.

- For this project you are expected to use an adjustable easel (or have a good reason not to.)
- Pay attention to how big the photograph is on the paper. If the photographs are different sizes, there needs to be a reason other than a technical problem. The size must be intentional. What size paper you use is entirely up to you. It can be as small as you like or as big as you like.
- If your photographs involve text think about how you will present the text. On a separate sheet of paper or on the photographic paper? What kind of writing utensil? Where on the paper is the most appropriate place to put the text, what size, what should the text type look like?

**PROPOSAL GUIDELINES FOR SELF DIRECTED PROJECT.** Tell the truth. Posing is transparent and you'll never know when you get it right. Talk about your questions, not your answers. A good question is much more engaging than a formulated conclusion. Be specific even if you are working with abstract concepts. Describe the specific parameters.

Artist Proposal Skeleton to be typed (in this order)

1. Description of proposed project. This should be the title of the work, the media, genre, and subject.
2. One sentence that encompasses the main questions of your piece: This should define the parameters of the project. This is both to get people interested and to show that your piece has boundaries. What does your project include and what doesn't it include? Be specific about the topic.
3. Narrative or linear description of the work - Create a pragmatic map of the mechanics of your project. Even in the most experimental work, there are structures. What are they?
4. Details of the working process that includes specifics of locations, access to locations, equipment you will work with, models (if shooting portraits), and who will work with you if another person is necessary to the work.
5. Camera, lighting, time of day, point of view, reasoning for formal choices.
6. Address general problems with your photographic work that this project will negotiate? This is important - .To have a sense of where your work fails to head towards a goal of change for the better.
7. Closing statement. Close up with a hopeful goal for your work, addressing the present tense. Example: I am truly excited about this project. I feel that (title) will give voice to ideas that touch us on a daily basis, a search for sanctuary and forgiveness for past failures.

---

### **Take Home Final**

Write a one page Artist Statement about your final photographic project.

The artist statement may be a first-person narrative or a semi-detached artist's statement and should answer the following questions in essay form.

How is the subject you chose important to you? What were your motivations for the project? What are the subjective underpinnings (specific and relevant influences, experiences or impulses that lead you to pick this subject? How did pursuing this subject advance your practice? What motivated you to do this work?

What aesthetic decisions did you make in relation to this subject?

What impact might your subject have in society?

This statement should be uploaded with the semester's course work.

Assessment:

Ability to follow directions

Quality of documentation

Depth and sophistication of artist statement

Relationship between images and statement

### **Explanation of Grading**

Note students are welcome to redo an assignment from start to finish for a higher grade with permission of the instructor and within a relevant time frame as determined by the instructor.

**GRADES:**

**B** Work shows intellectual risk and consistent effort. Emphasis is placed on producing well-conceived, thoughtful and interesting work. Work is technically proficient (students work is of good quality), falls within the guidelines of assignments and produces work consistent with the content of the assignments given. Assignment is completed on time and student is present and on time for both critique days and participates fully in class discussions and critiques.

**A** Excellent in all capacities exceeds all requirements and expectations.

**C** May show inadequate technical skills, work may be conceptually underdeveloped. Lacks effort or may show inconsistent effort. Does not consistently participate in class discussions. May not turn in assignment on time. May be missing work.

**D** lacks effort necessary to show development of skills and ideas.

**F** missing/late work, Work lacks effort and development of skills and ideas.

---

**BREAKDOWN:**

#1 Photogram/Pinholes	10%
#2 Walk	10%
#3 Displacement + contact sheets	10%
#4 Documents/final test + contact sheets	10%
Presentation on an artist	10%
Fiber Print	5%
Proposal for self-directed project	5%
#5 self-directed project	25%
Reading Inquires, field trips, off campus lectures & participation:	10%
Final statement/documentation	5%
<hr/>	
	100%

Course work will be evaluated on a 10-point scale. 9-10 will represent an A, 8-9 the B range, 7-8 the C range, 6-7 the D range, etc.

Photography is in many ways an eye motor skill in looking at and recording light. Active experimentation and physically making things without delay will produce the best results in this course even if at times the results initially fail. In the end it's what you've made that will determine how much you accomplish in this class.

**Projects are graded on:**

**Conceptual merit:** your projects should be compelling and well thought out. They will be evaluated in terms of degree of ambition and complexity of content and form and should also reflect a growing understanding of the art historical and theoretical concepts discussed in class.

### **Relationship of composition and formal elements to content including attention to light**

**Technical execution and effort:** in addition to the overall level of skill you bring to your projects, they will be evaluated for the degree to which they answer the technical requirements of your idea, and the amount of effort evident in the project.

**Planning, organization, experimentation:** because the overall process is often the most challenging and innovative aspect of art-making, your project grade will take into account the level of thought and preparation of your work at each stage: from initial proposal, through all stages of development, to the presentation of the final piece.

Expect approximately 8 hours a week of outside work, including the majority of your printing/lab time.

### **Grading and Attendance Policy:**

7 absences, excused or unexcused (3.5 weeks of class missed) in this course will result in a failing grade in the course regardless of course work. More than 3 absences may result in a lower grade in the course. Should a student fall significantly behind, consult the Withdraw date as listed in the USC academic calendar. The University encourages you to stay home if you are feeling at all unwell. No medical excuse is needed for an absence.

Be on time for class. Studies show students take in the most information in the first twenty minutes of class and essential information is given during this time. The course utilizes the entire course time. Showing up for part of the class but not the whole class is considered an absence.

Improving photographic skills comes from making, looking at, reading about, discussing, and critiquing photographic artworks. This close looking at photographic practice and meaning requires being in class actively engaged in the materials and class discussions which build on each other. Attendance is taken at all meetings. A student who misses several classes may not understand how far they have falling behind so make a point of being in class.

Students are responsible for reading the syllabus and calendar, and meeting all requirements listed when absent.

### **Assignment Submission Policy**

Assignments are due for presentation at the beginning of each critique day. **If you are late to class on critique day, it will be assumed you are in the lab and unprepared and your assignment will be considered late.** Late assignments will be marked down one letter grade for each delinquent class.

As written work is discussed on the day it is due, it is not accepted late or via email. If a student's printer is broken they are welcome to hand write inquiries. Inquiries that fail to demonstrate working knowledge of the readings will be returned with no credit.

Don't fall behind, if you do, make it your responsibility to catch up. If you know you are going to miss a class, please email me ahead of time and plan to submit work early.

### **Grading Timeline**

Standard timelines for returning work and giving feedback is 2 week.

### **Additional Policies**

It is required that the student be present at critique. Do not plan other events during class time generally.

After a first warning, students who persist in disruptive activities such as: sleeping, texting, emailing or online browsing for purposes other than class research, will result in an absence for that class session. If such activities persist the student will be asked to withdraw from the class due to disruptive activities. Electronic devices need to be stowed during lectures and discussions.

#### *Academic Integrity*

The University of Southern California is foremost a learning community committed to fostering successful scholars and researchers dedicated to the pursuit of knowledge and the transmission of ideas. Academic misconduct is in contrast to the university's mission to educate students through a broad array of first-rank academic, professional, and extracurricular programs and includes any act of dishonesty in the submission of academic work (either in draft or final form).

This course will follow the expectations for academic integrity as stated in the [USC Student Handbook](#). All students are expected to submit assignments that are original work and prepared specifically for the course/section in this academic term. You may not submit work written by others or "recycle" work prepared for other courses without obtaining written permission from the instructor(s). Students suspected of engaging in academic misconduct will be reported to the Office of Academic Integrity.

Other violations of academic misconduct include, but are not limited to, cheating, plagiarism, fabrication (e.g., falsifying data), knowingly assisting others in acts of academic dishonesty, and any act that gains or is intended to gain an unfair academic advantage.

The impact of academic dishonesty is far-reaching and is considered a serious offense against the university and could result in outcomes such as failure on the assignment, failure in the course, suspension, or even expulsion from the university.

For more information about academic integrity see the [student handbook](#) or the [Office of Academic Integrity's website](#), and university policies on [Research and Scholarship Misconduct](#).

#### *Course Content Distribution and Synchronous Session Recordings Policies*

USC has policies that prohibit recording and distribution of any synchronous and asynchronous course content outside of the learning environment.

Recording a university class without the express permission of the instructor and announcement to the class, or unless conducted pursuant to an Office of Student Accessibility Services (OSAS) accommodation. Recording can inhibit free discussion in the future, and thus infringe on the academic freedom of other students as well as the instructor. ([Living our Unifying Values: The USC Student Handbook](#), page 13).

Distribution or use of notes, recordings, exams, or other intellectual property, based on university classes or lectures without the express permission of the instructor for purposes other than individual or group study. This includes but is not limited to providing materials for distribution by services publishing course materials. This restriction on unauthorized use also applies to all information, which had been distributed to students or in any way had been displayed for use in relationship to the class, whether obtained in class, via email, on the internet, or via any other media. ([Living our Unifying Values: The USC Student Handbook](#), page 13).

### Supplementary Materials

#### **All students need:**

#### **Starter kit (optional) \$37.90 –(note photographic paper is needed the second day of classes)**

Paid via the photo lab - Jon Wingo's office with Discretionary funds. The 4D Handbook has directions for adding money to discretionary accounts. The starter kit includes:

- 01—roll HP5+ 35mmx36 Film
- 20—Sheets Ilford 8x10 RC Paper (Pearl)
- 02—5x7 Negative Sleeves

Please note a surcharge for Fiber Paper to be used at IFT later (typically 3 sheets of 11 x 14 or 2 sheets of 16 x 20 paper) .

35mm manual camera with manual focus, shutter speed and aperture. *It is possible to borrow cameras from the beginning photo lab for three days at a time*

Batteries for camera as necessary. Check before second week of school that it is functional.

Camera manual - often available *online or as you tube videos*.

Film: HP5 400 speed 36 exposures 10 rolls minimum (the more film shot, more options develop and better results occur – you need not purchase all film at the same time.)

Photographic paper: 100 sheets Ilford Multigrade IV RC Deluxe pearl black and white paper.

Minimum size 8 x 10 inches. If you are already an experienced printer, consider moving up in size, or a different paper.

Negative sleeves - **7 strips of 5**. (split pack with classmate)

Sealed notebook for your negatives. – such as Vue All Archival Safe-T Binder

Canned air or negative blower brush

Q-tips, Masking Tape

Color Grease pencil or red china marker

Folder to turn assignments in with

Closed toe shoes, LONG PANTS, Old t-shirt and Towel

Valid Library ID card for Lab Access – bring on **Thursday** for registration

#### **Photography Stores - Ask for student discounts**

Freestyle - 5124 Sunset Blvd. Cross Street Normandie. Tel. 323 660-3460 [www.freestylephoto.biz](http://www.freestylephoto.biz)

Samy's - On 200 S. Fairfax at 3rd street. [www.samys.com](http://www.samys.com)

B & H [www.bhphotovideo.com](http://www.bhphotovideo.com) they also sell equipment.

### **Course Schedule: A Weekly Breakdown** (subject to change )

#### **Week 1**

M 8/21

Introduction & materials

Demo pinhole cameras and darkroom chemistry

**Bring student ID, & photo paper to next class.** For paper, starter kit can be purchased in class 8/23)  
HW: bring small objects to class to make photograms with.

W 8/23

**Bring starter kit and valid USC ID card w/ Library code**

**Lab Tech** Jon Wingo introduces lab policies. Paperwork for checkout.  
Presentation and in class demo of *photograms*  
Lab - Hands on Experiments in pinhole cameras and photograms

**Assignment #1** 5 - 10 experimental prints **Due W 9/7**

**HW Reading (1):** on blackboard *The Second Coming* by Kaja Silverman from The Miracle of Analogy or The History of Photography, Part 1 scroll down to chapter 1 **8/28**

Bring small objects/newspapers, etc to make photograms with to next class.

## Week 2

M 8/ 28

Introduction Parameters for Artist presentation

**Inquiry Due** lecture and discussion the phenomena of photography  
LAB Pinhole cameras and photographs

**HW:** work on pinhole photographs & photograms

**Bring a camera to class 8/30**

W 8/30

**Demo film camera**

Demo making a positive from a paper negative  
Demo writing/drawing on prints with sharpie before development  
Lab prepare photograms/pinholes for Critique

**Assignment #2** 1 contact sheet, negative, print, and written description of print  
**due: 9/27**

**HW:** Research artists and pick three you would like to present on. List in order of reference and email to instructor by 9/11. First come first served. Work on project #1 &2

## Week 3

M 9/4

Labor Day Holiday

W 9/6

**Critique photograms and pinholes**

**Demo** Film loading for development

**HW: Bring exposed film in tank and negative sleeves to next class. Work on artist presentation**

## Week 4

M 9/11

**Bring film and negative sleeve to class**

**Demo** & in class film development

Demo film scanner

**DUE:** Three photographers names emailed to [jpaul@usc.edu](mailto:jpaul@usc.edu) use the following header: Jane Doe ART 255 Lawson, Deanna/Sherman Cindy/ (your name and the name of the three artists you are considering in order of 1<sup>st</sup>, 2<sup>nd</sup> and 3<sup>rd</sup> choices)

W 9/13

**Bring photo paper, negative in negative sleeve to class**

Discussion quality of negatives, images, editing.

**Demo** contact sheet and negative printing & filters

**HW: Reading (1):** *Against Interpretation*, by Susan Sontag (reading on blackboard)

**Inquiry Due: 9/20.** Work on darkroom prints/ reshoot as needed.

### Week 5

M 9/18 **Due** contact sheet, text prints so far  
Discussion contact sheet,  
Demo Burning and dodging, touching up prints

**HW:** research artists, work on project 2.

W 9/20 **Inquiry due Introduction Assignment #3 Displacement/indirect subjects**  
Guest Artist Lecture Jackie Castillo  
LAB

**HW Assignment #3** 6 + photographs 3 contact sheets **Due 10/18**

**HW:** complete project #2

### Week 6

M 9/25 **Critique #2**

**HW:** complete presentations/ shoot film/ make contact sheets

W 9/27 Lecture Portrait photography  
Flash photography demo w/ Jon Wingo

**HW Readings (3):** *What is a Document:* an exchange between Thomas Keenan and Hito Steyerl  
(on blackboard).

*Daido Moriyama on the Unending Newness of Photographs* <https://aperture.org/editorial/daido-moriyama-on-the-unending-newness-of-photographs/>

*ON Ming Smith: A life of Magical Thinking*

<https://gagosian.com/quarterly/2021/03/03/interview-ming-smith-magical-thinking/>

**Inquiry Due 10/4**

### Week 7

M 10/2 Demo Strobe Lights

W 10/4 LAB/meetings

**HW:** Complete project #3, shoot project #4

### Week 8

M 10/9 **Inquiry due.** Image Lecture & Discussion The Document & Projects 4 & 5  
Proposal writing introduced  
LAB

W 10/11 LAB

**HW work on project 3 & Artist. Presentations**

### Week 9

M 10/16 **Critique #3**

**HW:** Work on project 4/5

W 10/18 Presentations on Artists

**HW:** shoot and process film

**Week 10**

M 10/23 View The Nature of Photographs – Stephen Shore  
LAB/ individual meetings

W 11/25 Lecture Pushing and pulling film  
Demo Adjustable Easel  
LAB/ individual meetings

**HW:** prepare prints for fiber printing and work on assignment #4. Prepare proposal for project 5

**Week 11**

M 10/30 **Due typed 1-page proposal for Assign #5**  
LAB

**HW:** Complete project #4

W 11/1 **Critique #4**

**HW:** prep fiber print plan, work on project 5

**Week 12**

*During this week you should be shooting two rolls of film for the final project and develop them*

**Bring all negatives and prints to fiber printing day**

M 11/6 Fiber Printing group A

**HW:** shoot film & make contact sheets

W 11/8 Fiber Printing group B

**HW:** shoot film & make contact sheets

**Week 13**

***At least 2 rolls for your last creative assignment should be shot by now***

M 11/13 Take home Final -Artist Statements – introduced  
Final critique order determined.  
LAB

W 11/15 LAB/INDIVIDUAL MEETINGS

**Week 14**

**All contact sheets for self-directed due**

M 11/20 LAB/ INDIVIDUAL MEETINGS

W 11/22 **Thanksgiving Break**

**Week 15**

M 11/27 **Critique self-directed project**

W 11/29 **Critique self-directed project**

**Take Home Final Due: Friday Dec 8, 11 -1 pm** via google drop box invitation

Roski Talks – schedule subject to change – check link to confirm.

<https://roski.usc.edu/events>

Of note for this course:

Sept 12<sup>th</sup> Carolina Caycedo often uses video and focuses on the climate crisis from an indigenous perspective and is doing a very ambitious PST project bringing together artists, thinkers and activists from Alaska to the tip of South America - all on west coast.

Oct 10<sup>th</sup> Cosmo Whyte incorporates images into his sculpture and painting

Oct 24<sup>th</sup> Toni Smalls - a younger artist working in photo

Nov 7<sup>th</sup> Andy Campbell & Jennifer West

Nov 14<sup>th</sup> Pablo Jose Ramirez – New chief Curator Hammer Museum

<https://galleryplatform.la>

Get the AP SEE/SAW

<https://www.artforum.com/artguide/place/los-angeles?category=must+see> **CAAM** –

<https://caamuseum.org/exhibitions/2023/black-california-dreamin-african-americans-and-the-frontier-of-leisure>

**Justin LeRoy and Chloe Bass / Black California Dreaming': Claiming Space at America's Leisure Frontier**

**Center for Land Use Interpretation (CLUI)** – <https://clui.org/projects>

**The Getty** - Eugene Atget August 1 – Nov 5

[https://www.getty.edu/art/exhibitions/focus\\_atget/index.html](https://www.getty.edu/art/exhibitions/focus_atget/index.html)

**The Mistake Room** - <https://www.tmr.la/projects>

**The Hammer Museum** – Made in L.A. 2023 Acts of Living Oct 1 – Dec31

<https://hammer.ucla.edu/exhibitions/2023/made-la-2023-acts-living>

**MOCA Geffen** Olafur Eliasson. <https://www.moca.org/exhibition/olafur-eliasson>

**Hauser & Wirth** - <https://www.hauserwirth.com/hauser-wirth->

**ICA LA** – <https://www.theicala.org/en/exhibitions>

**JOAN** <https://joanlosangeles.org/>

**LACMA** – <https://www.lacma.org/art/exhibitions/current>

**PACE** <https://www.pacegallery.com/exhibitions/william-monk-west-of-nowhere/>

**M + B** <https://www.mplus.org/exhibitions/matthew-brandt> Sep 9 – Oct 7

**REDCAT** – The Feminist Art Program (1970-1975): Cycles of Collectivity

<https://www.redcat.org/events/2023/the-feminist-art-program>

**Spruth Magers** -Martine Symes till Aug 26th then see upcoming

<https://spruethmagers.com/exhibitions/upcoming/>

**LAXART** –currently closed <https://laxart.org/monuments>

**The Box Kim Jones, Walking Home** <https://theboxla.com/show.php?id=7268&type=upcoming>

**Commonwealth and Council** <https://commonwealthandcouncil.com/>

**Moskowitz Bayse** <http://www.moskowitzbayse.com/exhibitions-2023>

*Statement on Academic Conduct and Support Systems*

### **Academic Integrity:**

The University of Southern California is a learning community committed to developing successful scholars and researchers dedicated to the pursuit of knowledge and the dissemination of ideas. Academic misconduct, which includes any act of dishonesty in the production or submission of academic work, compromises the integrity of the person who commits the act and can impugn the perceived integrity of the entire university

community. It stands in opposition to the university's mission to research, educate, and contribute productively to our community and the world.

All students are expected to submit assignments that represent their own original work, and that have been prepared specifically for the course or section for which they have been submitted. You may not submit work written by others or "recycle" work prepared for other courses without obtaining written permission from the instructor(s).

Other violations of academic integrity include, but are not limited to, cheating, plagiarism, fabrication (e.g., falsifying data), collusion, knowingly assisting others in acts of academic dishonesty, and any act that gains or is intended to gain an unfair academic advantage.

The impact of academic dishonesty is far-reaching and is considered a serious offense against the university. All incidences of academic misconduct will be reported to the Office of Academic Integrity and could result in outcomes such as failure on the assignment, failure in the course, suspension, or even expulsion from the university.

For more information about academic integrity see [the student handbook](#) or the [Office of Academic Integrity's website](#), and university policies on [Research and Scholarship Misconduct](#).

Please ask your instructor if you are unsure what constitutes unauthorized assistance on an exam or assignment, or what information requires citation and/or attribution.

#### **Students and Disability Accommodations:**

USC welcomes students with disabilities into all of the University's educational programs. [The Office of Student Accessibility Services](#) (OSAS) is responsible for the determination of appropriate accommodations for students who encounter disability-related barriers. Once a student has completed the OSAS process (registration, initial appointment, and submitted documentation) and accommodations are determined to be reasonable and appropriate, a Letter of Accommodation (LOA) will be available to generate for each course. The LOA must be given to each course instructor by the student and followed up with a discussion. This should be done as early in the semester as possible as accommodations are not retroactive. More information can be found at [osas.usc.edu](http://osas.usc.edu). You may contact OSAS at (213) 740-0776 or via email at [osasfrontdesk@usc.edu](mailto:osasfrontdesk@usc.edu).

#### **Support Systems:**

[Counseling and Mental Health](#) - (213) 740-9355 – 24/7 on call

Free and confidential mental health treatment for students, including short-term psychotherapy, group counseling, stress fitness workshops, and crisis intervention.

[988 Suicide and Crisis Lifeline](#) - 988 for both calls and text messages – 24/7 on call

The 988 Suicide and Crisis Lifeline (formerly known as the National Suicide Prevention Lifeline) provides free and confidential emotional support to people in suicidal crisis or emotional distress 24 hours a day, 7 days a week, across the United States. The Lifeline is comprised of a national network of over 200 local crisis centers, combining custom local

care and resources with national standards and best practices. The new, shorter phone number makes it easier for people to remember and access mental health crisis services (though the previous 1 (800) 273-8255 number will continue to function indefinitely) and represents a continued commitment to those in crisis.

[Relationship and Sexual Violence Prevention Services \(RSVP\)](#) - (213) 740-9355(WELL) – 24/7 on call

Free and confidential therapy services, workshops, and training for situations related to gender- and power-based harm (including sexual assault, intimate partner violence, and stalking).

[Office for Equity, Equal Opportunity, and Title IX \(EEO-TIX\)](#) - (213) 740-5086

Information about how to get help or help someone affected by harassment or discrimination, rights of protected classes, reporting options, and additional resources for students, faculty, staff, visitors, and applicants.

[Reporting Incidents of Bias or Harassment](#) - (213) 740-5086 or (213) 821-8298

Avenue to report incidents of bias, hate crimes, and microaggressions to the Office for Equity, Equal Opportunity, and Title for appropriate investigation, supportive measures, and response.

[The Office of Student Accessibility Services \(OSAS\)](#) - (213) 740-0776

OSAS ensures equal access for students with disabilities through providing academic accommodations and auxiliary aids in accordance with federal laws and university policy.

[USC Campus Support and Intervention](#) - (213) 740-0411

Assists students and families in resolving complex personal, financial, and academic issues adversely affecting their success as a student.

[Diversity, Equity and Inclusion](#) - (213) 740-2101

Information on events, programs and training, the Provost's Diversity and Inclusion Council, Diversity Liaisons for each academic school, chronology, participation, and various resources for students.

[USC Emergency](#) - UPC: (213) 740-4321, HSC: (323) 442-1000 – 24/7 on call

Emergency assistance and avenue to report a crime. Latest updates regarding safety, including ways in which instruction will be continued if an officially declared emergency makes travel to campus infeasible.

[USC Department of Public Safety](#) - UPC: (213) 740-6000, HSC: (323) 442-1200 – 24/7 on call

Non-emergency assistance or information.

[Office of the Ombuds](#) - (213) 821-9556 (UPC) / (323-442-0382 (HSC)

A safe and confidential place to share your USC-related issues with a University Ombuds who will work with you to explore options or paths to manage your concern.

[Occupational Therapy Faculty Practice](#) - (323) 442-2850 or [otfp@med.usc.edu](mailto:otfp@med.usc.edu)  
Confidential Lifestyle Redesign services for USC students to support health promoting habits and routines that enhance quality of life and academic performance.